

THICK FILM CHIP RESISTOR NETWORK

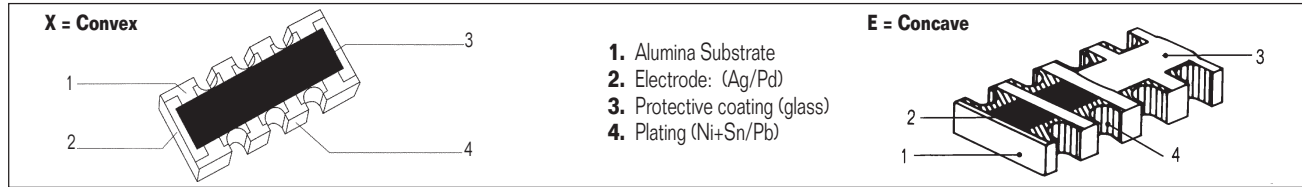

T Y P E Y C N

CONSTRUCTION



DIMENSIONS

(Unit:mm)

Mark	No. of Resistors	No. of Pins	A	B	C	D	E	F	G
YCN-10I 0402	2	4	0.35 ± 0.05	1.0 ± 0.05	0.65 ± 0.05	1.0 ± 0.05	0.35 ± 0.05	0.35 ± 0.05	0.25 ± 0.05
	4	8		2.0 ± 0.05	0.50 ± 0.05				
YCN-16I 0603	2	4	0.5 ± 0.15	1.6 ± 0.2	0.8 ± 0.05	1.6 ± 0.2	0.5 ± 0.1	0.4 ± 0.2	0.4 ± 0.15
	4	8		3.2 ± 0.2					
	8	16	0.45 ± 0.05	4.0 ± 0.2	0.5 ± 0.05	1.6 ± 0.2	0.5 ± 0.1	0.4 ± 0.2	0.4 ± 0.15
YCN 16B 0603	8	10	0.5 ± 0.05	3.2 ± 0.2	0.64 ± 0.05	1.6 ± 0.2	0.6 ± 0.1	0.4 ± 0.2	0.4 ± 0.15
YCN-32I 1206	4	8	0.9 ± 0.15	5.08 ± 0.3	1.27 ± 0.05	3.2 ± 0.2	0.6 ± 0.1	0.5 ± 0.2	0.5 ± 0.15

CIRCUIT

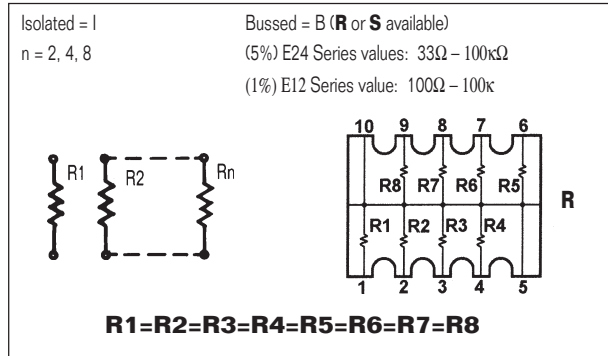

RATING

Item	YCN10	YCN16	YCN32
Number of Elements	2, 4	2, 4, 8	4
Power Rating Per Element	1/16W at 70°C	1/16W at 70°C	1/4W at 70°C
Resistance Tolerance	±5% (J)		±1% (F)
Resistance Range	10 Ω ~ 1M (J); E-24 Series		10 Ω ~ 560K (F) E-96 Series
T.C.R.	±200 PPM/°C (J)		±100 PPM/°C (F)
Max Working Voltage	25V	50V (I) / 25V (B)	200V
Max Overload Voltage	50V	100V (I) / 50V (B)	400V
Operating Temperature Range	-55°C ~ +125°C		

CHARACTERISTICS

Requirements	Characteristics	Test Method
Short time Over-Load	±2%	Rated Voltage × 2.5, 5 seconds
Soldering Heat	±3%	260±5°C, 10±1 seconds
Temperature Cycling	±2%	125°C (30 min) → normal (15 min) → -30°C (30 min) → normal (15 min), 5 cycles
Moisture Load-Life	±5%	1000 Hours
Load-Life	±5%	1000 Hours

ORDERING INFORMATION

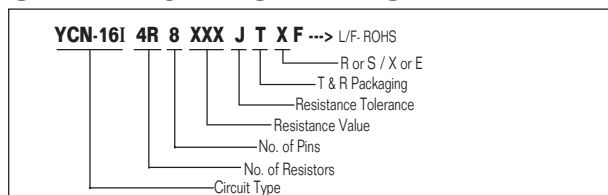

PACKAGING

(Unit:pcs)

Tape & Reel	Mark	Element		
		2R	4R	8R
	YCN-10I	10,000	10,000	N/A
	YCN-16I	5,000	5,000	4,000
	YCN-21B	N/A	N/A	5,000
	YCN-32I	N/A	4,000	N/A